

Snowmobile Installation Instructions

**Hitch Kits (p/n 8639-529, 8639-530, 8639-531,
8639-532, 8639-533, 8639-534)**

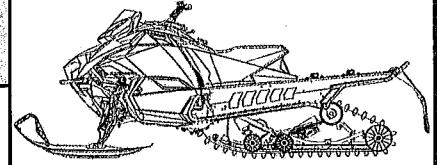

■ **NOTE:** Read these Installation Instructions thoroughly before beginning the installation process. Retain these Installation Instructions for future reference.

Kit includes:

p/n	QTY	DESCRIPTION
2706-548	1	Pivot Hitch
0706-727	1	Pintle Hitch
4707-523	1	Hitch Tube (ZR 129")
4707-524	1	Hitch Tube (ZR 137"/M 146")
4707-525	1	Hitch Tube (Riot 146"/M 154")
4707-528	1	Front Hitch Bracket (Right-Side)
4707-529	1	Front Hitch Bracket (Left-Side)
4707-530	1	Rear Hitch Bracket (Right-Side)
4707-531	1	Rear Hitch Bracket (Left-Side)
9621-285	1	Warning Decal
1623-206	4	Huck Rivet (M9) *
1623-257	28	Huck Rivet (M5) *
8408-855	2	Cap Screw (M8 x 55 mm) *
8427-802	2	Flange Lock Nut (M8) *
2653-333	1	Instructions

* Included in Hardware Kit (p/n 2655-247)

■ **NOTE:** Refer to the last page of this instruction for model application bracket layout.

Tools Required:

- Rivet Gun
- 10 mm Socket/Wrench
- 13 mm Socket/Wrench
- Torque Wrench
- 3/16-in. Drill Bit
- Power Drill

1. Secure the left-side rear hitch bracket and the left-side front hitch bracket to the hitch tube using six huck rivets. Repeat for the opposite side. See Fig. 1.

Fig. 1

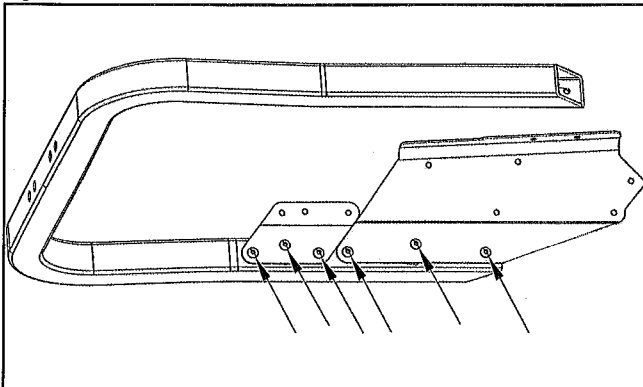

0755-304

■ **NOTE:** There is a notch in the bottom of the right-side brackets to differentiate from the left-side brackets.

2. Secure the pivot hitch or pintle hitch to the hitch tubes using two cap screws (M8 x 55 mm) and two M8 flange lock nuts. Tighten securely. See Fig. 2 or 3.

Fig. 2

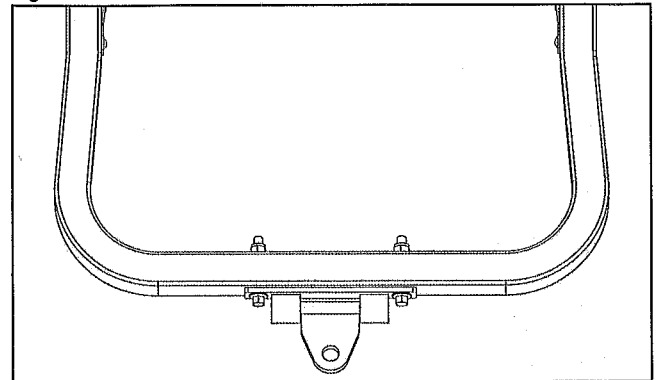

0755-306

Fig. 3

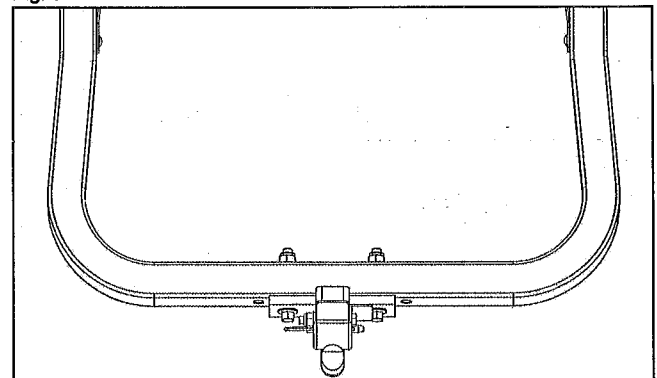

0755-307

3. Using a 3/16-in. drill bit, drill out the existing rivets (both sides) securing the rear bumper to the tunnel. See Fig. 4.

Fig. 4

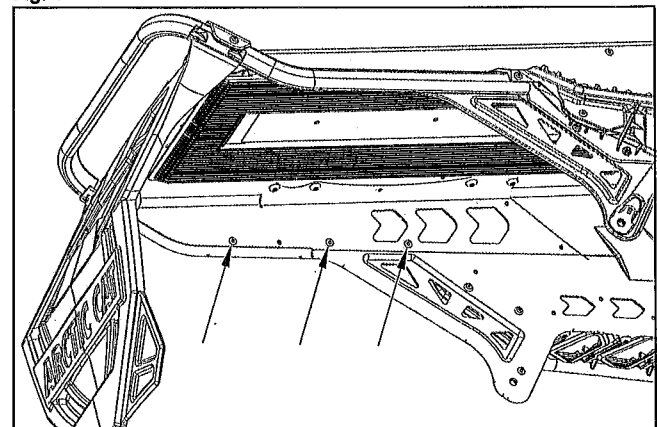

0755-308

4. Position the hitch kit assembly with the mounting locations (previously drilled). Secure the front brackets using four new M9 Huck Rivets and the rear brackets using two new M5 Huck Rivets. See Fig. 5.

Fig. 5

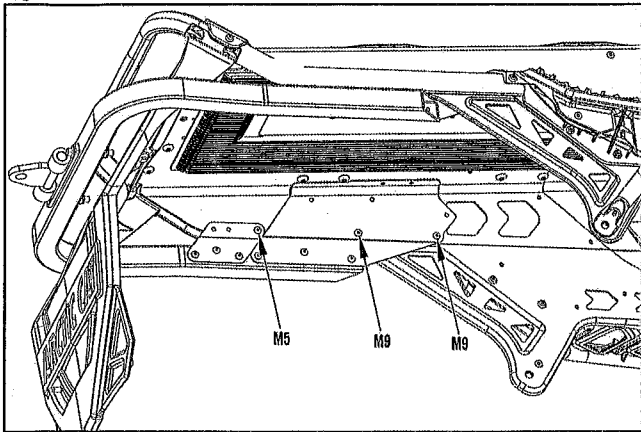

0755-309

5. Using a 3/16-in. drill bit, drill out the remaining 14 mounting locations using the brackets as a template. See Fig. 6.

Fig. 6

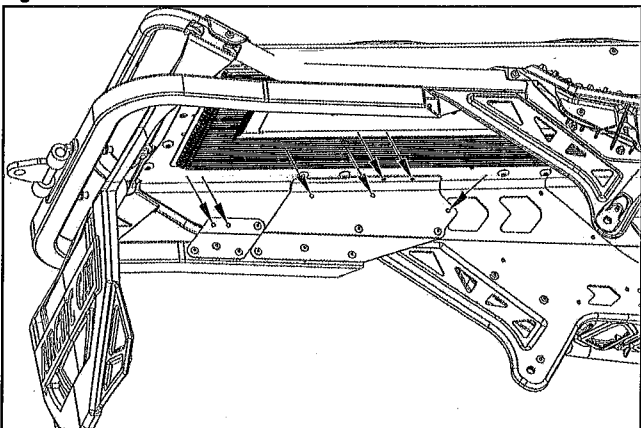

0755-310

6. Secure the front brackets to the tunnel using ten new M5 Huck Rivets from the outside of the tunnel. Secure the rear brackets to the tunnel and rear bumper using four new M5 Huck Rivets. See Fig. 7.

Fig. 7

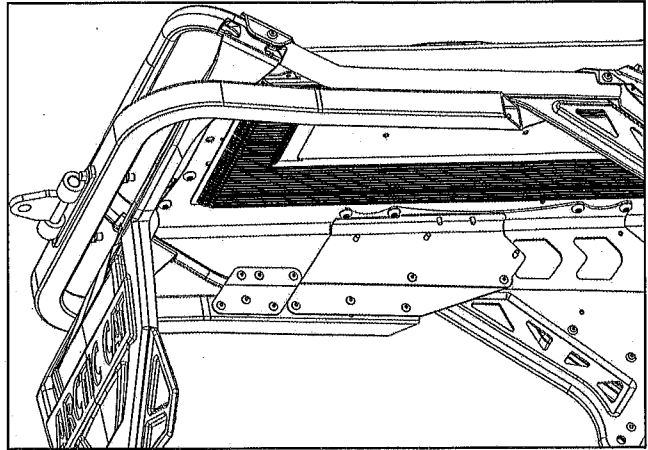

0755-311

7. Adhere the Warning Decal to the hitch tube. See Fig. 8.

Fig. 8

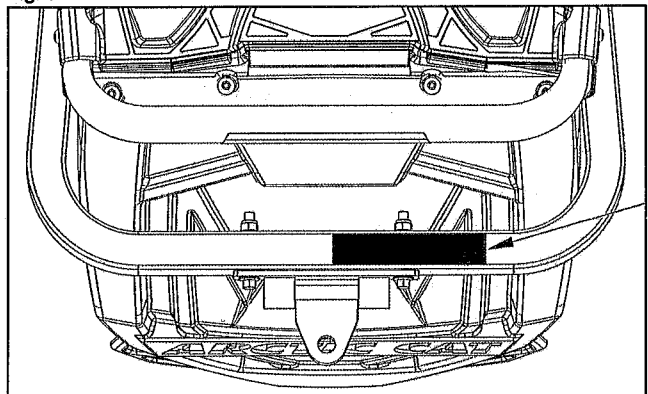

0755-312